

Call Transfer

If A and B are on a conversation and B may want A to transfer the call to C, three ways could be used to transfer the call: **Blind Transfer, Attended Transfer, and Semi-Attended Transfer.**

Blind Transfer:

- A press TRAN button to put B on hold, then A can dial the third number C and press TRAN button to call out. A will turn to hold status, and the LCD will display as Transferred
- After C answered it, or A press the MENU button to complete the transfer
- A will be disconnected from the call. B can talk to C

Attended Transfer:

- A press TRAN Button to put B on hold, then A can dial the third number C and press the OK or SEND button to call out
- After C answered it, A and C can have a private conversation without B hearing it, then A press the TRAN button to complete the transfer
- A will be disconnected from the call. B can talk to C

Semi-Atten Transfer:

- A press TRAN button to put B on hold, then A can dial the third number C and press the OK or SEND button to call out
- While C is ringing, A hang up or press the TRAN button. Then A will turn to hold status, and the LCD will display as Transferred
- A will be disconnected from the call, when C pick up, B can talk to C

Call Forward

- Enter the Call Forward path: MENU->Features->Forward
- There are 3 options: Always, Busy and No Answer
- Choose one of them, enter the number you want to forward. If you choose "No Answer", you should also set the "After Ring" option, Then press Save softkey to save the changes

Menu Instructions

Sub-Menu	Description
Status	User can check the status of IP phone: IP address, MAC, Firmware, etc.
Features	It includes some call feature settings, such as Forward, Call Waiting, DSS Keys, Key as Send, Hot Line, Anonymous Call, Auto Redial, DND, etc.
Settings	It includes the basic phone settings like Language, Time & Date, Ring Tone, Phone Volume and some advanced settings like Accounts, Network, Keypad Lock, Reset Factory, Set Password, Set AES Key, etc.
Messages	It allows the users to check the voice mail on the server.
History	You can check the call history here: All calls, Dial Calls, received Calls, Missed Calls, Forward Calls.
Directory	It shows the contacts of the phone.

The manual is only for reference, please take the object as the standard.
We reserve the right to improve or change the product and the user guide without notice.
You can download the latest user manuals from our website:
<http://www.yealink.com/en/download.asp?BigClassName=IP%20Phone>

V60.0



Support: 877.747.4284

help@atgvoice.com

Yealink
EASY VoIP

Enterprise IP Phone SIP-T20P
Quick Reference



Quick Reference

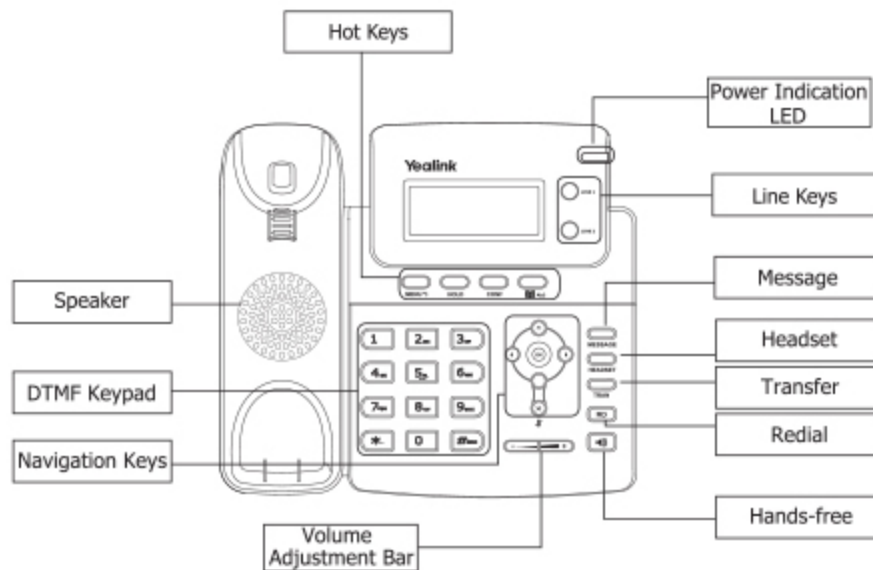

LEDs

Table 1 Line Keys

LED Status	Description
Steady green	The account is active
Blinking green	There is an incoming call to the account, or there is a call on hold
Off	The phone is in idle status whether registered/unregistered

Table 2 Power Indication LED

LED Status	Description
Steady green	Power on
Blinking green	There is an incoming call to the account, or there is a call on mute
Off	Power off

Table 3 Line Keys set to BLF

LED Status	Description
Steady green	The monitored account is in idle status
Fast Blinking green	There is an incoming call to the monitored account
Slow Blinking green	The monitored account is on an conversation
Off	It is inactive as BLF

Making a Call

Basic Phone Functions

You can make a call by pressing the Speaker/Line key or picking up the handset.

- **Dial number directly:** Dial the number directly, press SEND button to call out
- **Dial from Call History:** Go to History, use the navigation key to highlight the specific one, press SEND button to call out
- **Dial from Directory:** Press CONTACT to enter Directory, use the up/down button to choose the specific contact, press SEND button to call out
- **Re-dial:** Press RD button to enter the Dialed Calls interface, then use the Up/Down navigation keys to choose a record
During the conversation, you can alternate between Headset, Handset and Speaker by pressing the corresponding buttons or picking up the handset

Answering a Call

Answering an incoming call in the following ways:

- If you are on another call, press the corresponding Line key or OK button to answer it
- If you are not on another call, lift the handset using, or press the Speaker button to answer it using the speakerphone, or press the headset button to answer it using the headset
- You can also press (X) key to deny the incoming call

Muting a Call

- Press (X) button during a conversation to mute the current call, the icon  will be shown on the LCD, and the power indication LED will blink
- Press (X) again to get the microphone return to normal conversation

Volume Adjustment

- During the call, you can press the volume adjustment bars to adjust the volume

Putting a Call on Hold

- Press the HOLD button to put your active call on hold and then the corresponding line key will blink
- If there is only one call on hold, press the HOLD key again to retrieve it
- If there is more than one call on hold, press the up/down button to highlight the call, press HOLD key to retrieve the call

Voice Mail

- The presence of new Voice Mail messages is indicated in the idle screen, press MESSAGE, enter the desired password to get the voicemail in the server

Conference Call

- Press the CONF key during an active call
- The first call is placed on hold. You will hear a dial tone. Dial the number to conference in, then press SEND to dial out
- When the call is answered, press the CONF button, the conference call will now include you and the other two parties
- Hang up to disconnect all parties